



### I Applications

The compact and robust design of the Kiber NTE pump makes it ideal for transferring whole or destemmed grapes. And due to its design it can be installed right under the destemmer. It also can be used for the process of devatting.

### I Operating principles

Friction between the rotor and the stator creates a vacuum in the inlet area thereby helping the entry of the product into the pump.

The turning motion of the rotor makes the cavities between the rotor and the stator move forward and transport the product to the outlet.

### I Design and features

- Highly versatile.
- Easy to clean.
- Hopper with drain.
- Robust construction.
- Motor 3ph 230/460 V. Y, 440 V.Δ 60 Hz, IP-55 in compliance with the UL norm.
- Helical-Bevel gear units.
- Pump mounted on trolley.
- Connections: welding.
- Rotary wheels with brakes.



### I Materials

Parts in contact with the media	AISI 304 (1.4301)
Lantern	Carbon steel
Stator	NBR (specific composition for the wine industry applications)
Packing gland	PTFE
External surface finish	sandblasted

### I Options

- Liquid detector Max / Min.
- Remote control.
- Polyester CE electric panel.
- Electronic frequency converter.
- Connections Clamp, Garolla, Flanges, DIN, etc.
- Electromagnetic brakes in motor.



## I Technical specifications

Max. flow	90 m <sup>3</sup> /h	396 US GPM
Max. working pressure	6 bar	87 PSI
Max. working temperature	85 °C	185 °F

TYPE	Capacity <sup>(1)</sup> U.S. GPM	Capacity <sup>(1)</sup> Tn/h	Weight Lbs	Discharge Size DN	Speed rpm	Power Hp
NTE-60	35/48	8/11	420	4"	205	4
NTE-80	88/115	20/26	650	4"	220	7,5
NTE-90	110/150	25/34	730	6"	200	10
NTE-100	167/198	38/45	785	6"	200	10
NTE-120	290/374	66/85	1260	6"	200	25

(1) Nominal flow for grapes without stems at a pressure of 29 to 58 PSI

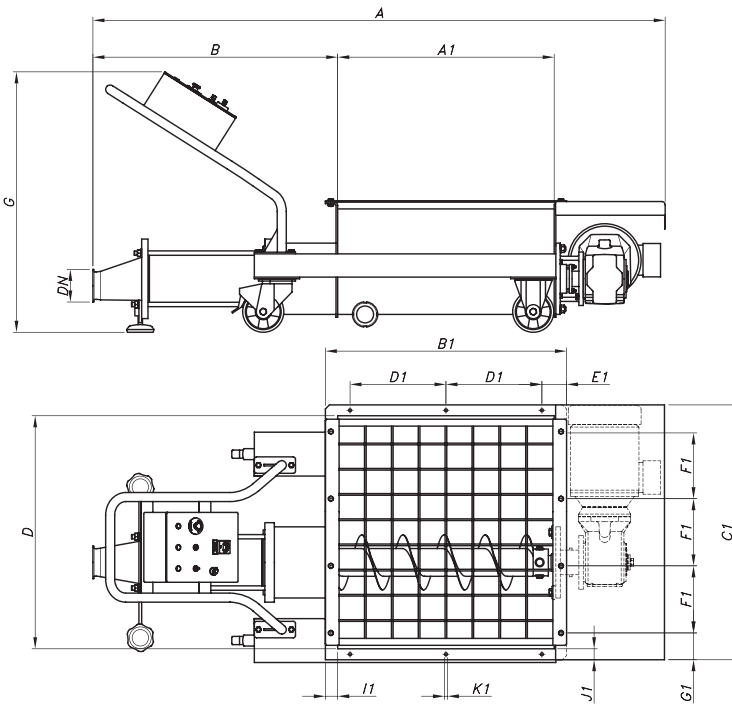

TYPE	A	A1	B	D	E	G	H	H2	CODE
NTE-60	63,39	27,55	22,05	29,5	32,87	35,43	15,95	5,83	D4005-0020503013U
NTE-80	82,28	31,10	35,24	33,46	37,40	37,40	18,70	6,69	D4008-0022505510U
NTE-90	82,68		35,63					6,18	D4009-0020007511U
NTE-100	85,83	38,78	39,37	43,30	19,29	6,41	6,41	D4010-0020007511U	
NTE-120	95,08	33,46						43,70	D4012-0020015012U

Dimensions with clamp connections

TYPE	HOPPER DIMENSIONS								
	B1	C1	D1	E1	F1	G1	I1	J1	K1
NTE-60	31,10	32,67	11,81	3,74	11,81	4,52	1,77	1,57	0,43
NTE-80	34,64	36,61	13,77	3,54	9,64	3,84	1,77	1,57	0,43
NTE-90									
NTE-100									
NTE-120	37,01	42,52	13,77	4,72	10,83	5,02	1,77	1,57	0,43



The information contained in this brochure is for guidance only. We reserve the right to modify any material or feature without notice in advance. For further information, please, consult our web site. [www.inoxpa.com](http://www.inoxpa.com)



FtNTE-3,USA-0810